

FIGURE P5-9

Data for problems 5-38 to 5-40 and 5-47

†5-43 Repeat Problem 5-40 using the data shown in Figure P5-10 instead.

†5-44 Repeat Problem 5-38 using the data shown in Figure P5-11 instead.

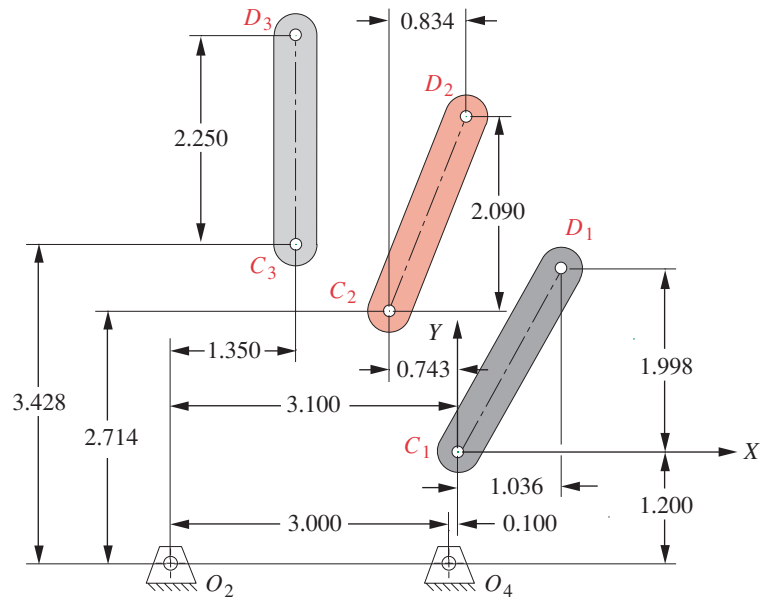

FIGURE P5-10

Data for problems 5-41 to 5-43 and 5-48

† These problems are suited to solution using *Mathcad*, or *TKSolver* equation solver programs. In most cases, your solution can be checked with program *FOURBAR*.