

FIGURE P3-12

Problem 3-27

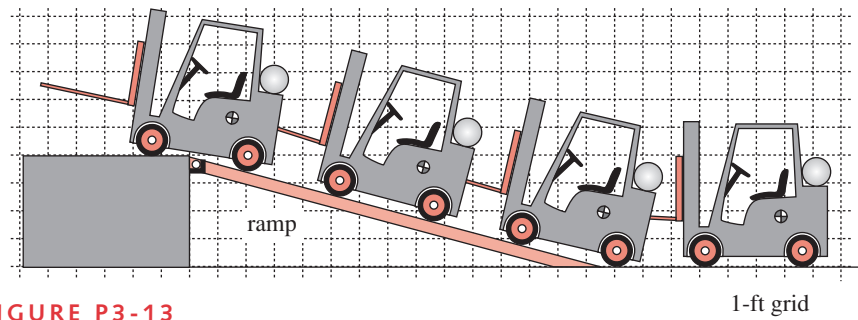

FIGURE P3-13

Problem 3-28

3-30 Run the computer model CASE2A for Case Study 2A (on the CD-ROM in several languages) and move the point of application of the crimp force along the jaw, recalculate, and observe the changes to the forces and moments.

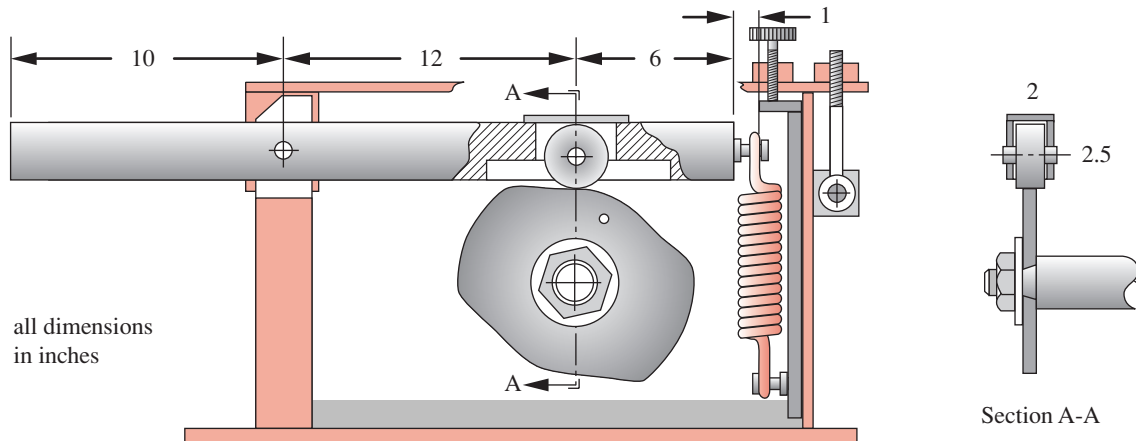

FIGURE P3-14

Problem 3-32

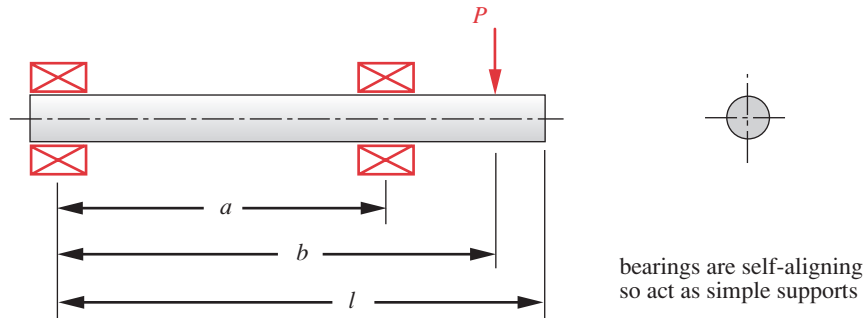

FIGURE P3-15

Problems 3-34 and 3-35

- 3-31 Run the computer model CASE3A for Case Study 3A (on the CD-ROM in several languages) and move the point of application of \mathbf{P} along the x direction, recalculate, and observe the changes to the forces and moments on the links. What happens when the vertical force \mathbf{P} is centered on link 3? Also, change the angle of the applied force \mathbf{P} to create an x component and observe the effects on the forces and moments on the elements.
- 3-32 Figure P3-14 shows a cam and cam-follower arm. If the load $P = 200$ lb, what spring force is needed at the right end to maintain a minimum load between cam and follower of 25 lb? Find the maximum shear force and bending moment in the follower arm. Plot the shear and moment diagrams.
- 3-33 Write a computer program or equation-solver model to calculate all the singularity functions listed in equations 3.17. Set them up as functions that can be called from within any other program or model.
- 3-34 A beam is supported and loaded as shown in Figure P3-15. Find the reactions, maximum shear, and maximum moment for the data given in the row(s) assigned from Table P3-2.
- *3-35 A beam is supported and loaded as shown in Figure P3-15. Write a computer program or equation-solver model to find the reactions and calculate and plot the loading, shear, and moment functions. Test the program with the data given in the row(s) assigned from Table P3-2.
- 3-36 A beam is supported and loaded as shown in Figure P3-16. Find the reactions, maximum shear, and maximum moment for the data given in the row(s) assigned from Table P3-2.

Table P3-2 Data for Problems 3-34 Through 3-41

Row	l (in)	a (in)	b (in)	P (lb) or p (lb/in)
<i>a</i>	20	16	18	1 000
<i>b</i>	12	2	7	500
<i>c</i>	14	4	12	750
<i>d</i>	8	4	8	1 000
<i>e</i>	17	6	12	1 500
<i>f</i>	24	16	22	750

* Answers to these problems are provided in Appendix D.

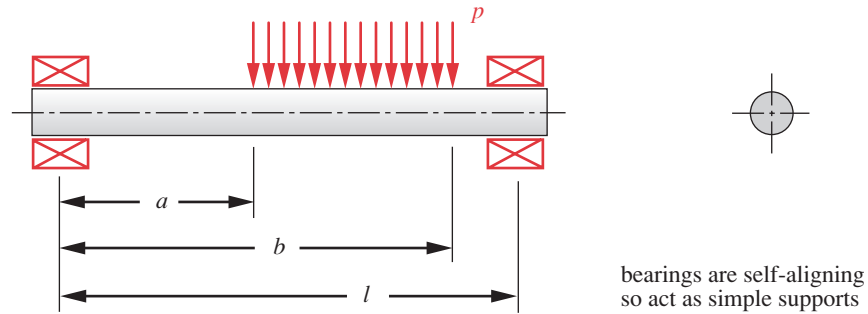
**FIGURE P3-16**

Problems 3-36 and 3-37

- 3-37 A beam is supported and loaded as shown in Figure P3-16. Write a computer program or equation-solver model to find the reactions and calculate and plot the loading, shear, and moment functions. Test the program with the data given in the row(s) assigned from Table P3-2.
- 3-38 A beam is supported and loaded as shown in Figure P3-17. Find the reactions, maximum shear, and maximum moment for the data given in the row(s) assigned from Table P3-2.
- 3-39 A beam is supported and loaded as shown in Figure P3-17. Write a computer program or equation-solver model to find the reactions and calculate and plot the loading, shear, and moment functions. Test the program with the data given in the row(s) assigned from Table P3-2.
- 3-40 A beam is supported and loaded as shown in Figure P3-18. Find the reactions, maximum shear, and maximum moment for the data given in the row(s) assigned from Table P3-2.
- 3-41 A beam is supported and loaded as shown in Figure P3-18. Write a computer program or equation-solver model to find the reactions and calculate and plot the loading, shear, and moment functions. Test the program with the data given in the row(s) assigned from Table P3-2.

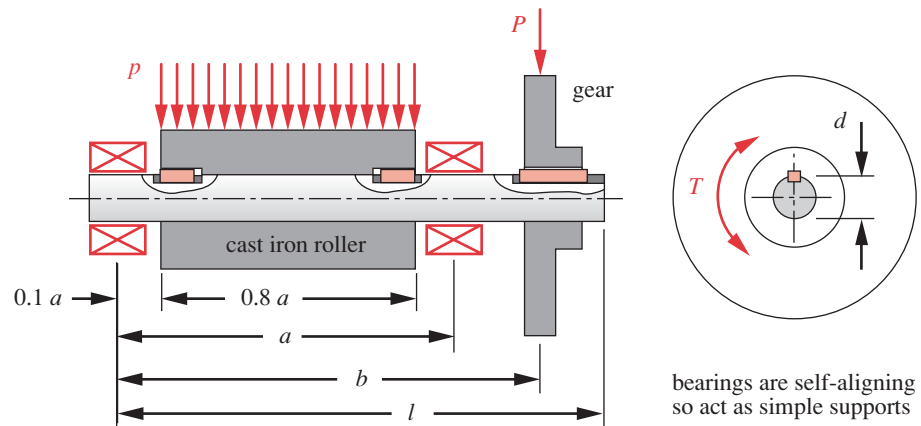
**FIGURE P3-17**

Problems 3-38 and 3-39

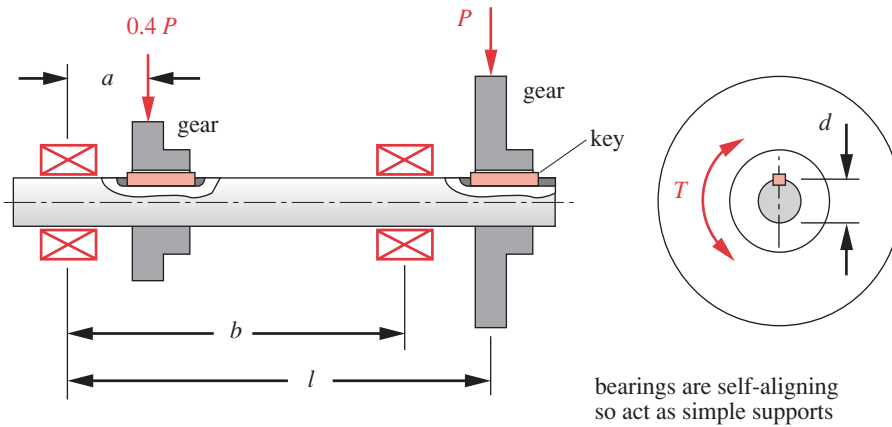

FIGURE P3-18

Problems 3-40 and 3-41

- 3-42 A 1000-kg speedboat reaches a speed of 16 kph at the instant it takes up the slack in a 100-m-long tow rope attached to a surfboard carrying a 100-kg passenger. If the rope has $k = 5 \text{ N/m}$, what is the dynamic force exerted on the surfboard?
- 3-43 Figure P3-19 shows an oil-field pump jack. For the position shown, draw free-body diagrams of the crank (2), connecting rod (3) and walking beam (4) using variable names similar to those used in Case Studies 1A and 2A. Assume that the crank turns slowly enough that accelerations can be ignored. Include the weight acting at the CG of the walking beam and the crank but not the connecting rod.
- 3-44 For the pump jack of Problem 3-43 and the data of Table P3-3, determine the pin forces on the walking beam, connecting rod, and crank and the reaction torque on the crank.

Table P3-3

Problem 3-44

R_{12}	13.20 in @ 135°
R_{14}	79.22 in @ 196°
R_{32}	0.80 in @ 45°
R_{34}	32.00 in @ 169°
R_P	124.44 in @ 185°
F_{cable}	2970 lb
W_2	598 lb
W_4	2706 lb
θ_3	98.5°

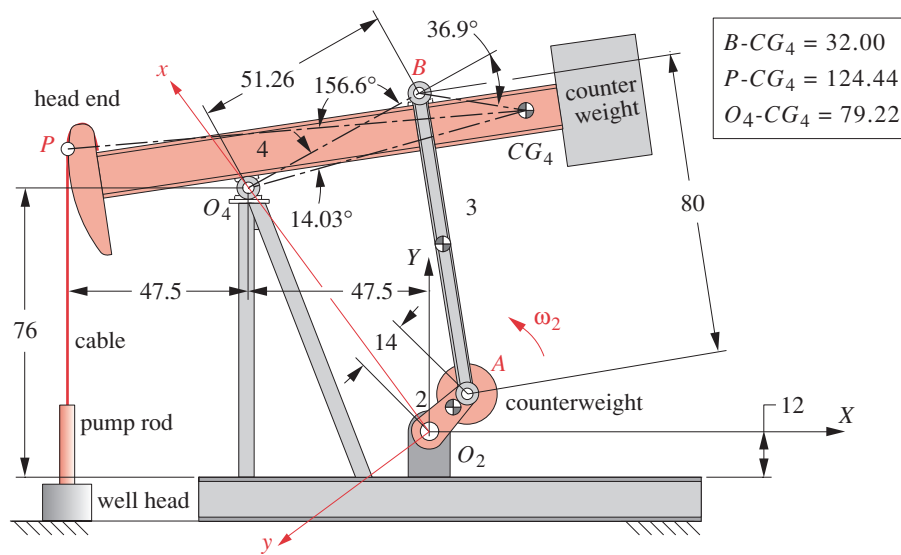

FIGURE P3-19

all linear dimensions are in inches

Problems 3-43 and 44

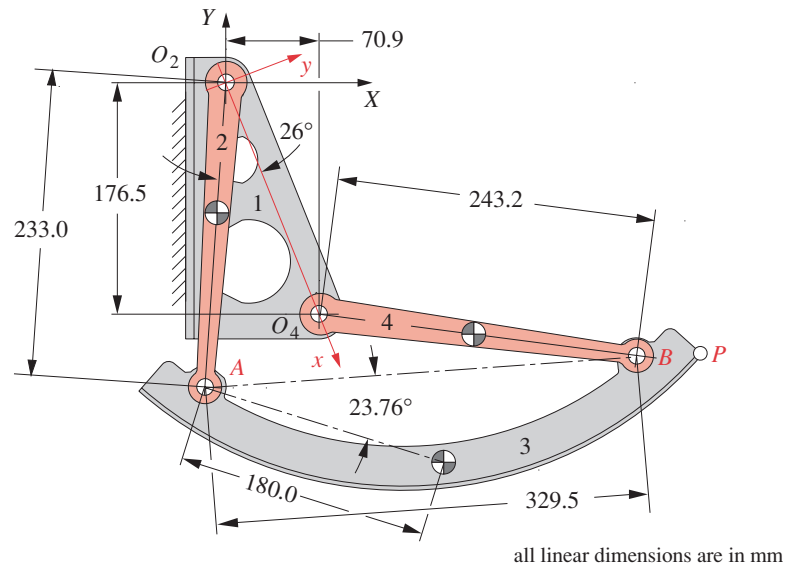

FIGURE P3-20

all linear dimensions are in mm

Problems 3-45 and 46

Table P3-4

Problem 3-46

R_{23}	180 mm @ 160.345°
R_{43}	180 mm @ 27.862°
W_3	45 N
θ_2	85.879°
θ_4	172.352°

- 3-45 Figure P3-20 shows an aircraft overhead bin mechanism in end view. For the position shown, draw free-body diagrams of links 2 and 4 and the door (3) using variable names similar to those used in Case Studies 1A and 2A. There are stops that prevent further clockwise motion of link 2 (and the identical link behind it at the other end of the door) resulting in horizontal forces being applied to the door at points A. Assume that the mechanism is symmetrical so that each set of links 2 and 4 carry one half of the door weight. Ignore the weight of links 2 and 4 as they are negligible.
- 3-46 For the overhead bin mechanism of Problem 3-45 and the data of Table P3-4, determine the pin forces on the door (3), and links 2 & 4 and the reaction force on each of the two stops.
- 3-47 A particular automobile wheel suspension consists of two A-arms, the wheel (with tire), a coil spring, and a shock absorber (damper). The effective stiffness of the suspension (called the “ride rate”) is a function of the coil spring stiffness and the tire stiffness. The A-arms are designed to give the wheel a nearly vertical displacement as the tire rides over bumps in the road. The entire assembly can be modeled as a spring-mass-damper system as shown in Figure 3-15(b). If the sprung mass (mass of the portion of the vehicle supported by the suspension system) weighs 675 lb, determine the ride rate that is required to achieve an undamped natural frequency of 1.4 Hz. What is the static deflection of the suspension for the calculated ride rate?
- *3-48 The independent suspension system of Problem 3-47 has an unsprung weight (the weight of the axle, wheel, A-arms, etc.) of 106 lb. Calculate the natural frequency (hop resonance) of the unsprung mass if the combined tire and coil spring stiffness (ride rate) is 1100 lb/in.
- 3-49 The independent suspension system of Problem 3-47 has a sprung weight of 675 lb and a ride rate of 135 lb/in. Calculate the damped natural frequency of the sprung mass if the damping coefficient of the shock absorber is a constant 12 lb-sec/in.
- 3-50 Figure P3-22 shows a powder compaction mechanism. For the position shown, draw free-body diagrams of the input arm (2), connecting rod (3) and compacting ram (4)

* Answers to these problems are provided in Appendix D.

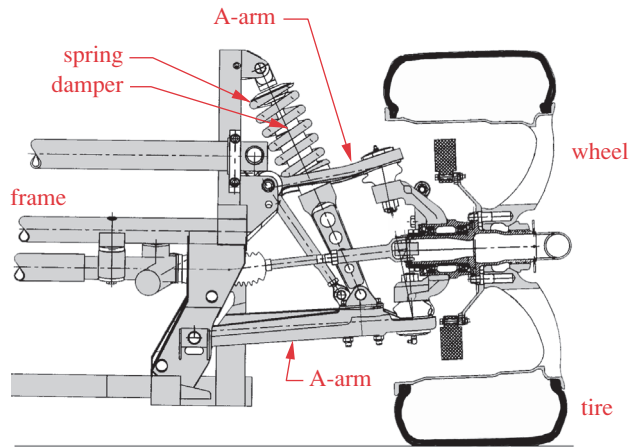

3

FIGURE P3-21

Problems 3-47 through 49 Viper suspension - Courtesy of DaimlerChrysler Corporation

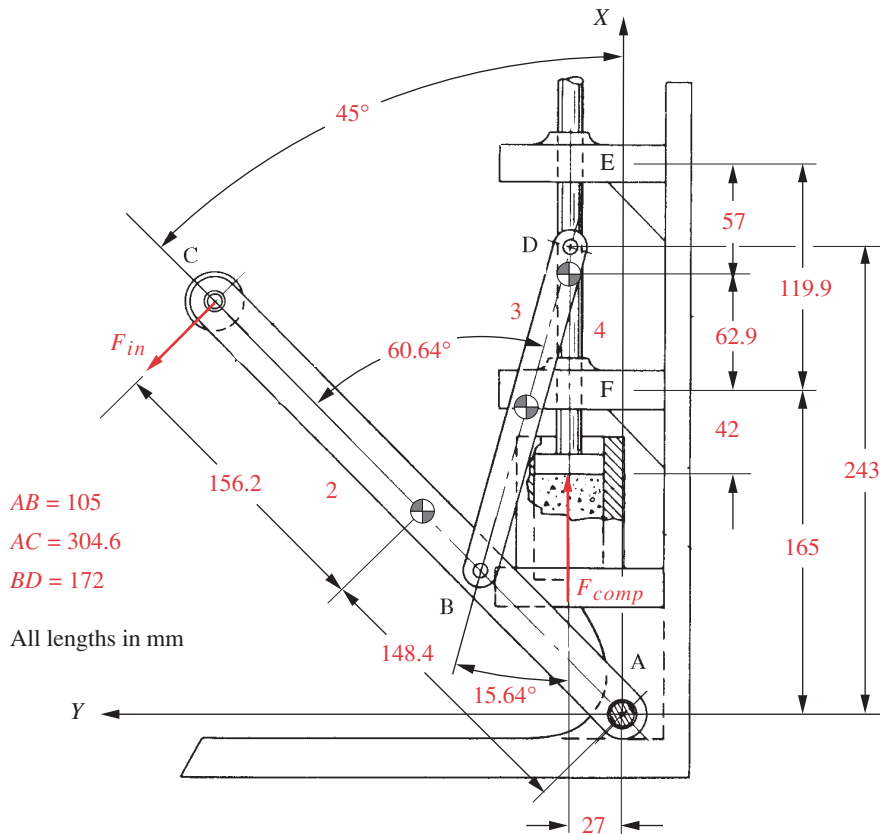

FIGURE P3-22

Problems 3-50 and 3-51

Table P3-5

Problem 3-51

R_{12}	148.4 mm @ 315°
R_{14E}	57.0 mm @ 90°
R_{14F}	62.9 mm @ 270°
R_{32}	42.9 mm @ 74.36°
R_{23}	87.6 mm @ 254.36°
R_{34}	15.0 mm @ 90°
R_{43}	87.6 mm @ 74.36°
R_{in}	152.6 mm @ 225°
R_p	105.0 mm @ 270°
F_{comp}	100 N
θ_3	254.36°

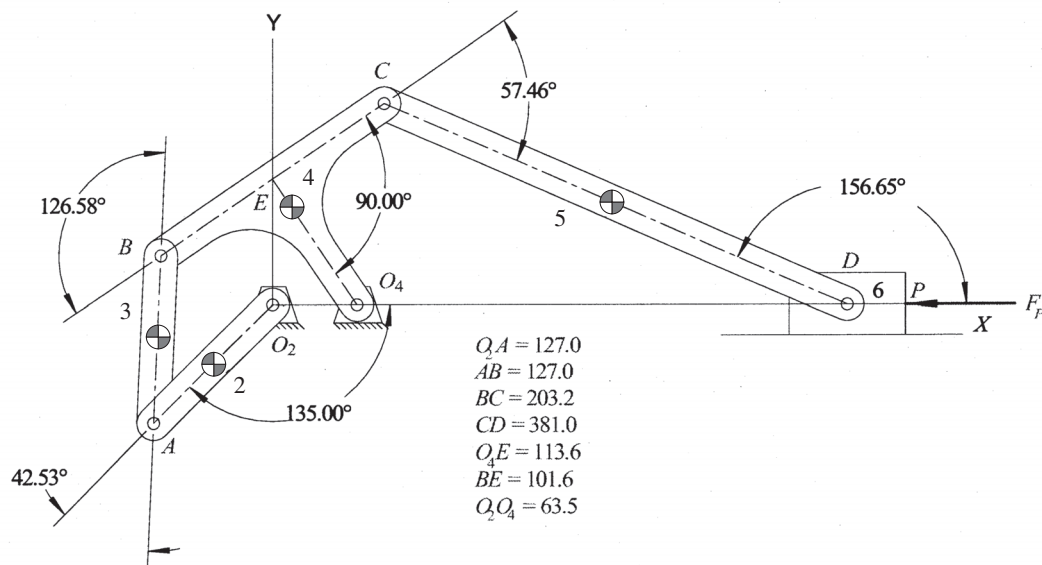

FIGURE P3-23

Problems 3-52 and 3-53

Table P3-6

Problem 3-53

R_{12}	63.5 mm @ 45.38°
R_{14}	93.6 mm @ -55.89°
R_{23}	63.5 mm @ 267.80°
R_{32}	63.5 mm @ 225.38°
R_{34}	103.5 mm @ 202.68°
R_{43}	63.5 mm @ 87.80°
R_{45}	190.5 mm @ 156.65°
R_{54}	103.5 mm @ 45.34°
R_{65}	190.5 mm @ -23.35°
F_P	85 N
θ_3	87.80°
θ_5	156.65°

using variable names similar to those used in Case Studies 1A and 2A. Assume that the input arm turns slowly enough that accelerations can be ignored. Ignore the weights of the arm, connecting rod, and compacting ram. Neglect friction. All links are symmetrical with CG in the center.

- 3-51 For the compaction mechanism of Problem 3-50 and the data of Table P3-5, determine the pin forces on the compacting ram, connecting rod, and input arm. The position vectors (R_{xx}) in the table locate points of force application on a link versus the CG of the link on which the force acts. All links are symmetrical with CG in the center.
- 3-52 Figure P3-23 shows a drag link slider crank mechanism. For the position shown, draw free-body diagrams of links 2 through 6 using variable names similar to those used in Case Studies 1A and 2A. Assume that the crank turns slowly enough that accelerations can be ignored. Ignore the weights of the links and any friction forces or torques. All links are symmetrical with CG in the center.
- 3-53 For the drag link slider crank mechanism of Problem 3-52 and the data of Table P3-6, determine the pin forces on the slider, connecting rods, and crank and the reaction torque on the crank. The position vectors (R_{xx}) in the table locate points of force application on a link versus the CG of the link on which the force acts. All links are symmetrical with CG in the center.